

# COLD AIR GUNS

Adjustable Temperatures to  $-30^{\circ}\text{F}$  ( $-34^{\circ}\text{C}$ )



## Features...

- Exceptionally reliable – no moving parts
- Produces cold air to  $100^{\circ}\text{F}$  ( $56^{\circ}\text{C}$ ) below inlet air temperature
- Quiet operation – meets OSHA noise specifications
- Uses only filtered compressed air
- No refrigerants – no EMI/RFI interference
- Low-pressure air output helps clear chips and debris



Ours dry  
and frost free

Competitors  
frost and condensation



**NEW!**

## Frost-Free Versatile Spot Cooling for Machining & More

Cold Air Guns use filtered compressed air and vortex tube technology to produce sub-zero air for numerous industrial spot cooling applications. With no moving parts to wear out, the internal vortex tube converts factory compressed air into a cold air stream, producing temperatures down to as low as  $-30^{\circ}\text{F}$  ( $-34^{\circ}\text{C}$ ). Cold Air Guns are used in various industrial processes, fabrication, assembly and packaging as a versatile spot cooling device.

- Widely used in milling, drilling, turning and other metalworking operations
- Machining of plastics, composites, wood and other materials
- Surface grinding, drill and tool sharpening
- Cooling molds and molded pieces
- CNC routers, blades and band saws
- Spot cooling of parts and assemblies
- Industrial sewing and textiles
- Setting hot melts and adhesives
- Thermal testing sensors
- Cooling welds and solders

## Increase dry machining speeds up to 36% and extend tool life up to 50%

Most popular applications involve cooling during the machining of metals, plastics, wood, rubber, ceramics and other materials. Cold air machining outperforms mist coolants and substantially increases tool life and feed rates on dry machining operations. The effective cooling from a Cold Air Gun can eliminate heat-related parts growth while improving part tolerance and surface finish quality.

## Adjustable Cold Air Gun Systems available now in 900, 1500 and 2500 BTUH models

Our extended line of Cold Air Gun models is ideal for a wide variety of machining operations and other spot cooling needs. The Cold Air Gun's easily adjustable temperature and airflow settings and instant on/off capability make it simple to adapt its cold air output to the application.

- Eliminates the mess, expense and safety concerns of using mist coolants
- Cools parts to reduce normalization time and hold tight part tolerance
- Avoids secondary parts cleaning after machining
- Provides single turn temperature adjustment knob
- Offers magnetic base for easy "machine-to-machine" portability
- Frost-free models eliminate frost and condensation on directable outlet nozzle

**VORTEC**  
The Originator of Vortex Tube Products

# COLD AIR GUN PRODUCT LINE

Adjustable Temperatures to -30°F (-34°C)

610-1, 620-1, 630-1, 611-1, 621-1, 631-1  
Cold Air Guns Only



610, 620, 630, 611, 621, 631  
Cold Air Gun Systems



Option for Standard Cold Air Gun Models



## Cold Air Gun Models

Frost-Free Model No.	Standard Model No.	Description	Air Consumption scfm / slpm	Max. Cooling Capacity BTUH / kCal/hr
611-1	610-1	Cold Air Gun Only	15 / 425	900 / 227
611	610	Cold Air Gun System	15 / 425	900 / 227
621-1	620-1	Cold Air Gun Only	25 / 708	1500 / 378
621	620	Cold Air Gun System	25 / 708	1500 / 378
631-1	630-1	Cold Air Gun Only	35 / 991	2500 / 630
631	630	Cold Air Gun System	35 / 991	2500 / 630

Cold Air Gun Systems include the Cold Air Gun, magnetic mounting base and a 5 micron Auto-Drain compressed air filter.

Available accessories: #610-30 Dual Outlet Flex Nozzle for 610, 620 and 630 models.

(Air consumption and cooling capacity values at 100 psig [6.9 bar] operating pressure.)

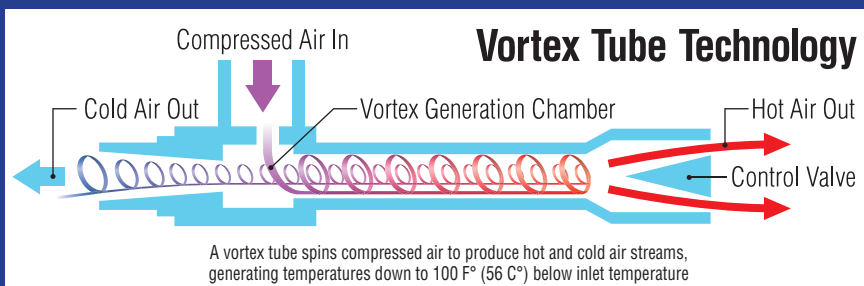

## How Cold Air Guns Generate Frigid Air

Fluid (air) that rotates around an axis (like a tornado) is called a vortex. A vortex tube creates cold air and hot air by forcing compressed air through a generation chamber, which spins the air at a high rate of speed (1,000,000 RPM) into a vortex. The high-speed air heats up as it spins along the inner walls of the tube toward the control valve. A percentage of the hot, high speed air is permitted to exit at the valve. The remainder of the (now slower) air stream is forced to counterflow

up through the center of the high-speed air stream in a second vortex. The slower moving air gives up energy in the form of heat and becomes cooled as it spins up the tube. The chilled air passes through the center of the generation chamber finally exiting through the opposite end as extremely cold air. Vortex tubes generate temperatures down to 100 F° (56 C°) below inlet air temperature. The control valve located in the hot exhaust end can be used to adjust the temperature drop and rise for all vortex tubes.

## Magnetic Base

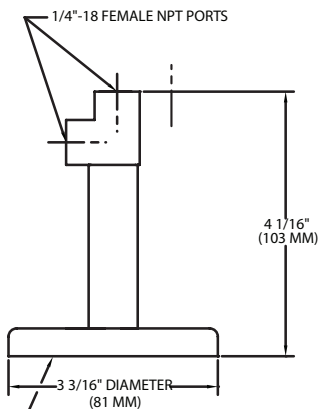

80 LB (36 kg) PULL STRENGTH MAGNET  
MAGNETIC BASE SUPPLIED WITH THESE MODELS:  
610, 611, 620, 621, 630 AND 631

## Cold Air Gun

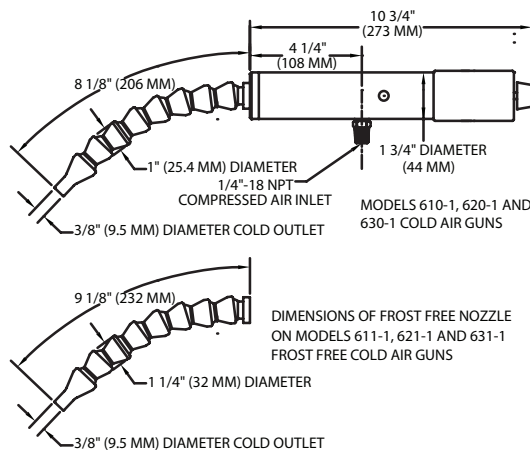

VT-SS-1002 (E) © 2011 All rights reserved

Developing compressed air solutions to improve manufacturing productivity for over 50 years!

800.745.5355 • www.Vortec.com • techsupport@vortec.com



Confident in the quality and reliability of Vortec products, we extend an unparalleled, 10-Year Warranty on Cold Air Guns.

**VORTEC**  
The Originator of Vortex Tube Products